

CAP

ASTM/ASME A234
ANSI B 16.9 / B 16.28
MSS SP-43

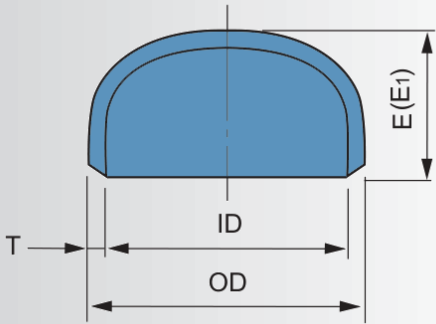

NOMINAL PIPE SIZE	DIMENSIONS							WALL THICKNESS		
	Outside Diameter at Bevel: D OD		Inside Diameter at Bevel: D ID		Length			Sch. No.	t	
	inch	mm	inch	mm	E	Limiting Wall Thickness For Length	E		inch	mm
1/2"	0.840"	21.34	0.622" 0.546" 0.464" 0.252"	15.80 13.88 11.78 6.40	25.4	4.57	25.4	Std/40 40s XS/80 80s 160 XXS	0.109" 0.147" 0.188" 0.294"	2.77 3.73 4.78 7.47
3/4"	1.050"	26.67	0.824" 0.742" 0.612" 0.434"	20.93 18.85 15.55 11.03	25.4	3.81	25.4	Std/40 40s XS/80 80s 160 XXS	0.113" 0.154" 0.219" 0.308"	2.87 3.91 5.56 7.82
1"	1.315"	33.4	1.049" 0.957" 0.815" 0.599"	26.64 24.30 20.70 15.22	38.1	4.57	38.1	Std/40 40s XS/80 80s 160 XXS	0.133" 0.179" 0.250" 0.358"	3.38 4.55 6.35 9.09
1 1/4"	1.660"	42.16	1.380" 1.278" 1.160" 0.896"	34.86 32.46 29.46 22.76	38.1	4.83	38.1	Std/40 40s XS/80 80s 160 XXS	0.140" 0.191" 0.250" 0.382"	3.56 4.85 6.35 9.70
1 1/2"	1.900"	48.26	1.610" 1.500" 1.338" 1.100"	40.90 38.10 33.98 27.94	38.1	5.08	38.1	Std/40 40s XS/80 80s 160 XXS	0.145" 0.200" 0.281" 0.400"	3.68 5.08 7.14 10.16
2"	2.375"	60.32	2.067" 1.939" 1.687" 1.503"	52.50 49.24 42.84 38.18	38.1	5.59	38.1	Std/40 40s XS/80 80s 160 XXS	0.154" 0.218" 0.344" 0.436"	3.91 5.54 8.74 11.07

CAP

ASTM/ASME A234
ANSI B 16.9 / B 16.28
MSS SP-43

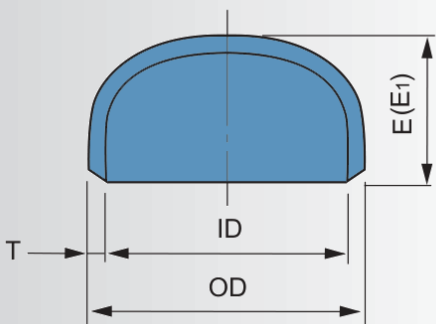

NOMINAL PIPE SIZE	DIMENSIONS							WALL THICKNESS		
	Outside Diameter at Bevel:D OD		Inside Diameter at Bevel:D ID		Length			Sch. No.	t	
	inch	mm	inch	mm	E	Limiting Wall Thickness For Length	E			
mm					mm	mm				
2 1/2"	2.875"	73.02	2.469"	62.70	38.1	7.11	50.8	Std/40 40s XS/80 80s 160 XXS	0.203"	5.16
			2.323"	59.00					0.276"	7.01
			2.125"	53.98					0.375"	9.52
			1.771"	44.98					0.552"	14.02
3"	3.500"	88.90	3.068"	77.92	50.8	7.62	63.5	Std/40 40s XS/80 80s 160 XXS	0.216"	5.49
			2.900"	73.66					0.300"	7.62
			2.624"	66.66					0.438"	11.12
			2.300"	58.42					0.600"	15.24
4"	4.500"	114.30	4.026"	102.26	63.5	8.64	76.2	Std/40 40s XS/80 80s 120 160 XXS	0.237"	6.02
			3.726"	97.18					0.387"	8.56
			3.624"	92.06					0.438"	11.12
			3.438"	87.32					0.531"	13.49
			3.125"	80.06					0.674"	17.12
5"	5.563"	141.30	5.047"	128.20	76.2	9.65	88.9	Std/40 40s XS/80 80s 120 160 XXS	0.258"	6.55
			4.813"	122.24					0.375"	9.53
			4.563"	115.90					0.500"	12.70
			4.313"	109.54					0.625"	15.88
			4.063"	103.20					0.750"	19.05
6"	6.625"	168.30	6.065"	154.08	88.9	10.92	101.6	Std/40 40s XS/80 80s 120 160 XXS	0.280"	7.11
			5.761"	146.36					0.432"	10.97
			5.501"	139.76					0.562"	14.27
			5.187"	131.78					0.719"	18.26
			4.897"	124.40					0.864"	21.95

CAP

ASTM/ASME A234
ANSI B 16.9 / B 16.28
MSS SP-43

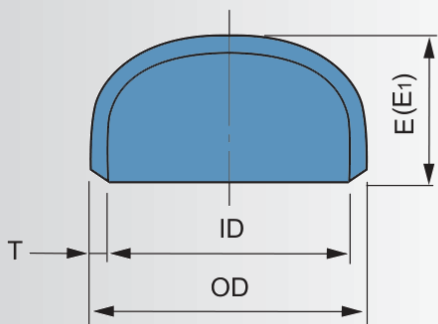

NOMINAL PIPE SIZE	DIMENSIONS							WALL THICKNESS		
	Outside Diameter at Bevel:D OD		Inside Diameter at Bevel:D ID		Length			Sch. No.	t	
	inch	mm	inch	mm	E	Limiting Wall Thickness For Length	E		inch	mm
8"	8.625"	219.08	7.981" 7.625" 8.125" 7.813" 7.437" 7.187" 7.001" 6.813" 6.875"	202.72 193.68 206.38 198.46 188.90 182.56 178.54 173.06 174.64	101.6	12.70	127.0	STD/40 40s XS/80 80s 20 60 100 120 140 160 XXS	0.322" 0.500" 0.250" 0.406" 0.594" 0.719" 0.812" 0.906" 0.875"	8.18 12.70 6.35 10.31 15.09 18.26 20.62 23.01 22.22
10"	10.750"	273.05	10.020" 9.750" 9.562" 10.250" 9.312" 9.062" 8.750" 8.500"	254.51 247.65 242.87 260.35 236.53 230.17 222.25 215.89	127.0	12.70	152.4	STD/40 40S XS/80S 60 80 20 100 120 140/XXS 160	0.365" 0.500" 0.594" 0.250" 0.719" 0.844" 1.000" 1.125"	9.27 12.70 15.09 6.35 18.26 21.44 25.40 28.58
12"	12.750"	323.80	12.000" 11.750" 12.250" 11.938" 11.374" 11.062" 10.750" 10.500" 10.126"	304.76 298.40 311.10 303.18 288.84 280.92 273.00 266.64 257.16	152.4	12.70	177.8	STD 40S XS/80S 20 40 80 100 120 140 160	0.375" 0.500" 0.250" 0.406" 0.688" 0.844" 1.000" 1.125" 1.312"	9.52 12.70 6.35 10.31 17.48 21.44 25.40 28.58 33.32

CAP

ASTM/ASME A234
ANSI B 16.9 / B 16.28
MSS SP-43

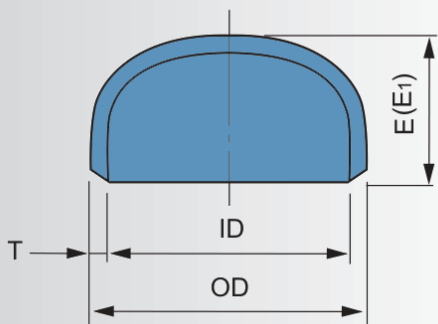

NOMINAL PIPE SIZE	DIMENSIONS							WALL THICKNESS		
	Outside Diameter at Bevel:D OD		Inside Diameter at Bevel:D ID		Length			Sch. No.	t	
	inch	mm	inch	mm	E	Limiting Wall Thickness For Length	E		inch	mm
14"	14.000"	355.60	13.250" 13.376" 13.124" 13.000" 12.812" 12.500" 12.124" 11.812" 11.500" 11.188"	336.56 339.76 333.34 330.20 325.42 317.50 307.94 300.02 292.10 284.18	165.1	12.70	190.5	STD 20 40 XS 60 80 100 120 140 160	0.375" 0.312" 0.438" 0.500" 0.594" 0.750" 0.938" 1.094" 1.250" 1.406"	9.52 7.92 11.13 12.70 15.09 19.05 23.83 27.79 31.75 35.71
16"	16.000"	406.40	15.250" 15.000" 15.376" 14.688" 14.312" 13.938" 13.562" 13.124" 12.812"	387.36 381.00 390.56 373.08 363.52 354.02 344.48 333.36 325.42	177.8	12.70	203.2	STD XS/40 20 60 80 100 120 140 160	0.375" 0.500" 0.312" 0.656" 0.844" 1.031" 1.219" 1.438" 1.594"	9.52 12.70 7.92 16.66 21.44 26.19 30.96 36.52 40.49
18"	18.000"	457.20	17.250" 17.000" 17.736" 16.876" 16.500" 16.124" 15.688" 15.250" 14.876" 14.438"	438.16 431.80 441.36 428.66 419.10 409.56 398.48 387.36 377.86 366.72	203.2	12.70	228.6	STD XS 20 40 60 80 100 120 140 160	0.375" 0.500" 0.132" 0.562" 0.750" 0.938" 1.156" 1.375" 1.562" 1.781"	9.52 12.70 7.92 14.27 19.05 23.82 29.36 34.92 39.67 45.24

CAP

ASTM/ASME A234
ANSI B 16.9 / B 16.28
MSS SP-43

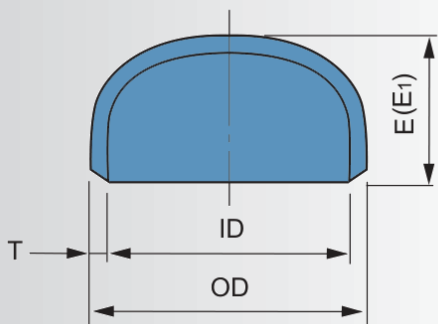

NOMINAL PIPE SIZE	DIMENSIONS							WALL THICKNESS																										
	Outside Diameter at Bevel:D OD		Inside Diameter at Bevel:D ID		Length			Sch. No.	t																									
	inch	mm	inch	mm	E	Limiting Wall Thickness For Length	E		inch	mm																								
20"	20.000"	508.0	19.250"	488.96	228.6	12.70	254.0	STD/20	0.375"	9.52																								
			19.000"	482.60							XS	0.500"	12.70																					
			18.812"	477.82										40	0.594"	15.09																		
			18.376"	466.76													60	0.812"	20.62															
			17.938"	455.62																80	1.031"	26.19												
			17.438"	442.92																			100	1.281"	32.54									
			17.000"	431.80																						120	1.500"	38.10						
			16.500"	419.10																									140	1.750"	44.45			
			16.062"	407.98																												160	1.969"	50.01
22"	22.000"	558.80	21.250"	539.76	254.0	12.70	254.0	STD/20	0.375"	9.52																								
			21.000"	533.40							XS	0.500"	12.70																					
			20.250"	514.36										60	0.875"	22.22																		
			19.750"	501.64													80	1.125"	28.58															
			19.250"	488.96																100	1.375"	34.92												
			18.750"	476.24																			120	1.625"	41.28									
			18.250"	463.56																						140	1.875"	47.62						
			17.750"	450.84																									160	2.125"	53.98			
24"	24.000"	609.60	23.250"	590.56	266.7	12.70	304.8	STD/20	0.375"	9.52																								
			23.000"	584.20							XS	0.500"	12.70																					
			22.624"	574.64										40	0.688"	17.48																		
			22.062"	560.38													60	0.969"	24.61															
			21.562"	547.68																80	1.219"	30.96												
			20.938"	531.82																			100	1.531"	38.89									
			20.376"	517.56																						120	1.812"	46.02						
			19.876"	504.86																									140	2.062"	52.37			
			19.312"	490.52																												160	2.344"	59.54

CAP

ASTM/ASME A234
ANSI B 16.9 / B 16.28
MSS SP-43

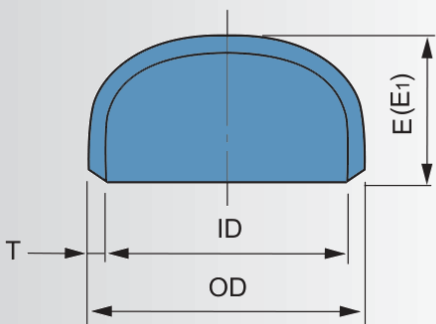

NOMINAL PIPE SIZE	DIMENSIONS							WALL THICKNESS		
	Outside Diameter at Bevel:D OD		Inside Diameter at Bevel:D ID		Length			Sch. No.	t	
	inch	mm	inch	mm	E	Limiting Wall Thickness For Length	E		inch	mm
26"	26.000"	660.40	25.250" 25.000"	641.36 635.00	266.7	-	-	STD XS	0.375" 0.500"	9.52 12.70
28"	28.000"	711.20	27.250" 27.000"	692.56 685.80	266.7	-	-	STD XS	0.375" 0.500"	9.32 12.70
30"	30.000"	762.00	29.500" 29.376" 29.250" 29.000"	749.30 746.16 742.96 736.60	266.7	-	-	STD XS	0.375" 0.500"	9.52 12.70
32"	32.000"	812.80	31.250" 31.200" 30.624"	793.76 787.40 777.84	266.7	-	-	STD XS 40	0.375" 0.500" 0.688"	9.52 12.70 17.48
34"	34.000"	863.60	33.250" 33.000" 32.624"	844.54 838.20 828.64	266.7	-	-	STD XS 40	0.375" 0.500" 0.688"	9.52 12.70 17.48
36"	36.000"	914.00	35.250" 35.000" 34.500"	894.96 888.60 875.90	266.7	-	-	STD XS 40	0.375" 0.500" 0.750"	9.52 12.70 19.05
38"	38.000"	965.20	37.250" 37.000"	946.16 939.80	304.8	-	-	STD XS	0.375" 0.500"	9.52 12.70
40"	40.000"	1016.00	39.250" 39.000"	996.96 990.60	304.8	-	-	STD XS	0.375" 0.500"	9.52 12.70
42"	42.000"	1066.80	41.250" 41.000"	1047.76 1041.40	304.8	-	-	STD XS	0.375" 0.500"	9.52 12.70
44"	44.000"	1117.60	43.250" 43.000"	1098.56 1092.20	342.9	-	-	STD XS	0.375" 0.500"	9.52 12.70
46"	46.000"	1168.40	45.250" 45.000"	1149.36 1143.00	342.9	-	-	STD XS	0.375" 0.500"	9.52 12.70
48"	48.000"	1219.20	47.250" 47.000"	1200.16 1193.80	342.9	-	-	STD XS	0.375" 0.500"	9.52 12.70